

## Pilot operated check, single, manual shut-off

VSO-SE-DL-DX

05.52.27 - X - Y - Z

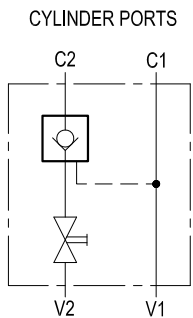

### Description

A tap, manually controlled by the operator, allows inlet flow from V2 to pass through the check valve to C2: as a result, the motion of the actuator (typically the extension and positioning of an outrigger) happens under the operator's direct sight. The valve is normally closed (checked) and virtually leak-free from C2 to V2 in order to prevent reverse motion. Flow outlet from C2 to V2 and reverse motion (i.e. outrigger retraction or lifting up) is possible with manual tap open and if sufficient pilot pressure is present at V1-C1 so that the pilot piston may push the poppet from its seat.

### Performance

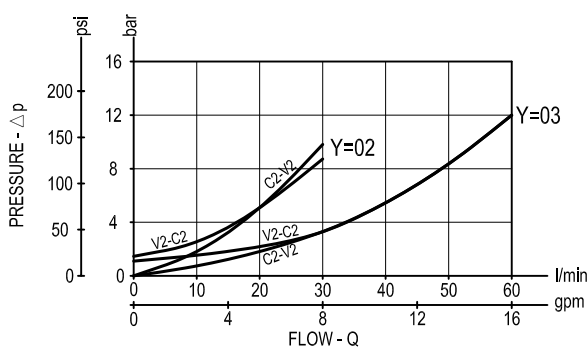

### Technical data

#### Hydraulic

Operating pressure	bar (psi)	up to 210 (3000)
Max. flow		see performance graph

#### General

Manifold material		Aluminium
Note: aluminium bodies are often strong enough for operating pressures exceeding 210 bar (3000 psi), depending from the fatigue life expected in the specific application. If in doubt, consult our Service Network.		
Weight		see "Dimensions"
Fluid temperature range	°C (°F)	between -30 (-22) and +100 (212)
Other technical data		see data sheet RE 18350-50

**Note:** for applications outside these parameters, please consult us.

Dimensions

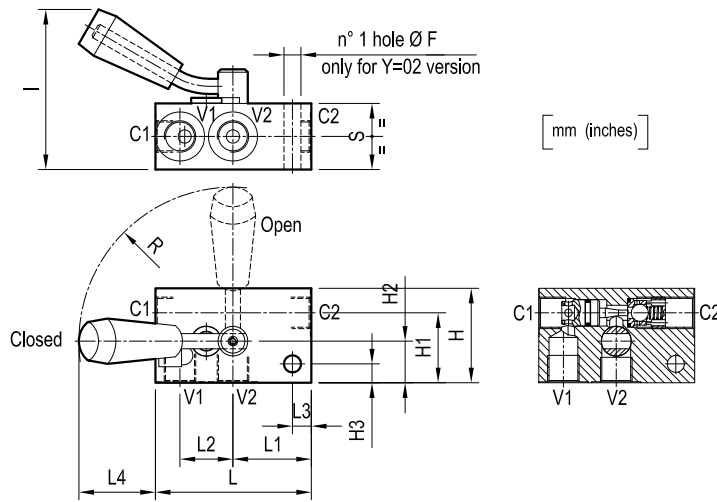

35 (1.38)	40.5 (1.6)	-	35 (1.38)	40.5 (1.6)	90.5 (3.56)	85 (3.35)	-	30 (1.18)	50 (1.97)	65 (2.56)	-	82 (3.23)	G 1/2	3.6 : 1	1 (2.2)
35 (1.38)	40.5 (1.6)	10 (0.39)	28 (1.1)	41.5 (1.63)	82.5 (3.25)	85 (3.35)	10 (0.39)	22 (0.87)	37 (1.46)	50 (1.97)	9 (0.35)	82 (3.23)	G 3/8	5.4 : 1	0.6 (1.3)
S	L4	L3	L2	L1	L	I	H3	H2	H1	H	F	R	Y	Pilot ratio	Weight kg (lbs)

Ordering code

<b>05.52.27</b>	<b>X</b>	<b>Y</b>	<b>Z</b>
-----------------	----------	----------	----------

Pilot operated check, single, manual shut-off

O-Ring on pilot piston

= 10 With O-Ring

SPRINGS

Cracking pressure  
bar (psi)

= 00

only for Y=02

1.6 (23)

only for Y=03

0.6 (9)

Port sizes	V1 - V2	C1 - C2
= 02	G 3/8	G 3/8
= 03	G 1/2	G 1/2

Type	Material number
05522710020000C	R930002345
05522710030000B	R930002349

Type	Material number